

UDC 004.4

DOI: 10.25140/2411-5363-2020-3(21)-274-280

Michal Kelemen, Peter Ján Sinčák

PROGRAMMABLE LOGIC CONTROLLER TRAINING STANDS FOR EDUCATIONAL PURPOSES

Urgency of the research. Programmable logic controller are devices for controlling of various systems also in industry. If controlled device is complicated, it is problem to debug application, because of risk of its damage. For this purpose is better to use hardware training stand for testing of your designed application.

Target setting. Training stand is as compact small device which is easy to move to another place. Also it allows to connect other hardware device for testing. Logical state hardware simulator is also designed for simulation of logic system with any user inputs with buttons or switches and also with coloured lights for visualisation of output state.

Actual scientific researches and issues analysis. Training set allows to make simulation of control system with real parts before its practical use with expensive controlled system, where any mistake can cause a huge economist loses, but errors occurred during the simulation on training set only make warning and shows the weak place on design.

Uninvestigated parts of general matters defining. The questions of the networked structure of programmable logic controller structures are uninvestigated, so the next research will be focused to this.

The research objective. The main goal is to create a compact device for training future application developers with a programmable logic controller, but it is also usable for developers from practice, who need to debug the program before installing it into real operation.

The statement of basic materials. Existing training sets are large and expensive devices that are not easy to carry and cannot be expanded. Working with such devices is quite complicated. The designed training stand is a flexible and easily portable device.

Conclusions. Main contribution is that students will gain practical experiences and skills that are essential for PLC programmers. This device supports also own creativity of students, because it allows to modify hardware composition. It uses the DIN rail system similar as in real installation cabinet. The stand also includes the human-machine interface for training of practical using of these devices.

Keywords: Programmable logic controller; controlling; hardware; human-machine interface; ladder.

Fig.: 10. References: 3.

Introduction. According to [1], millions of microprocessors are produced annually, but only less than 1 % is used in conventional computers. The vast majority are used as a control system in other embedded systems. Proof of this is the number of microprocessor-containing devices around us that we encounter on a daily basis. These include such devices as cars, ATMs, refrigerators, washing machines, dryers, dishwashers, copiers, CD and DVD drives, mobile phones, air conditioners, heating systems, aircraft, trains, traffic lights, gate systems, satellites, etc. In all products, their main task is to extend product properties and create intelligent product properties. The main goal is to make life easier for a person and increase their safety and comfort. In some products, such as automobiles, aircraft have dozens of such microprocessors integrated in those products.

Customers prefer products with a degree of intelligence that brings new features to the product that make it easier to use. A typical example is a car, which contains dozens of embedded microprocessors for the control of individual processes in the car. The aim is to increase the comfort of using the car and also human safety. Aircrafts are also filled with microprocessors, which take care of the safety of the aircraft and take on a number of complex and demanding tasks. Thus, a certain part of the responsibility is transferred to these microprocessors, which clearly make a person's life easier. Many other daily consumption products around us are filled with microprocessors and we often do not realize that only with their help some products can work. Often we don't even realize how dependent on these microprocessor-controlled systems we are.

A special part of microprocessor applications is “programmable logic controller” (also called “PLC”), which are the core mainly in industrial facilities, where they take over the function of controlling complex industrial processes. These are industrial control systems, that obtain information from sensors and then implement logical operations, where they compare the desired value of the variable with the actual one and implement an action intervention in the controlled system using actuators. PLC controllers are designed to handle real-time parallel control operations and are resistant to electrical noise and vibration and shock, which are very common in industrial environments.

The history of PLC controllers dates back to 1964, when the first PLC called MODICON 084 [2] was introduced in order to replace expensive and extensive panels with complicated structures composed of electromagnetic relays. The relay in this period was a module with a limited life and a speed of information processing was limited by the electromechanical principles of relay operation. Even then, it was a PLC system with exceptional mechanical robustness and the ability to operate continuously.

At present, PLC controllers are based on microprocessors and are placed in racks together with other electrical modules and are not normally accessible to ordinary users. For communication with the user, the PLCs are equipped with a human-machine interface (HMI), which allows a user to control the status of a controlled system and can intervene in the control process if required by the situation in the controlled process.

PLC control systems are installed in devices with high electrical voltage, where there is a risk of electric shock, and thus only the technician, who has the appropriate authorizations in connection with the safety of work with electrical equipment has direct access to the hardware of PLC control systems. In many cases, the controlled system is a technological system, the costs of which are high, so it is important that only authorized persons work with the PLC control system.

The main aim of this paper is to present the training set for educational purpose for students on bachelor and master study on studying “Industrial mechatronics” programme. Students have to prepare for designing control structure with PLC also from practical viewpoint. Students can build practical systems with real PLC and other parts used in real systems. This approach helps to bring more practical experiences to students and improve their capability and knowledge in area of design of control systems including the PLC controllers. PLC programmer cannot be a perfect specialist without practical knowledge. Also training set allows to make simulation of control system with real parts before its practical use with expensive controlled system, where any mistake can cause a huge economist loses, but errors occurred during the simulation on training set only make warning and shows the weak place on design. Also training set can allows to simulate abnormal situation, which cannot be trained on real systems as extreme low temperatures, extreme high velocities etc. [3].

1. PLC control system concept. Concept of controlled system based on PLC (fig. 1) consists of sensors of all relevant quantities. Another part is number of actuators as relays, motors, solenoids and pumps etc., which make a suitable action into controlled systems. The report about the processes to standard user can be shown on indicator lights or signal column also called light tower, buzzers etc. The user command can be obtained through the buttons or switches (also emergency stop buttons). If it is necessary, PLC also includes touchable LCD panel as human-machine interface (“HMI”).



Fig. 1. Concept of controlled system including the PLC controller

Programmable logic controller PLC (fig. 2) consists of main core unit, where the central processing unit CPU, all types of memories, communication busses and other support devices are placed. Inputs and outputs blocks are also placed on main core, but it is possible to expand main core with another extra blocks with requested inputs or outputs. As it shown on figure 2, the PLC receives information about the followed quantities from controlled process and PLC sends any commands (if it is necessary) to outputs and to any actuator to make any action on controlled process. There are two variants of power supply arrangement. Power supply with 24V output voltage can be as separate part or to be included in main core unit of PLC. Our application is running inside the main core. The application is developed on personal computer using the development tool related to type of used PLC. Some PLC also includes human-machine interface directly on main core unit or it is presented as another module installed somewhere in structure. The CPU unit of PLC provides a PROFINET port for communication over a PROFINET network. Additional modules are available for communicating over PROFIBUS, GPRS, RS485, RS232, IEC, DNP3, and WDC networks. If it is necessary, you can build network structure with more PLC units using the Profinet network (fig. 3).

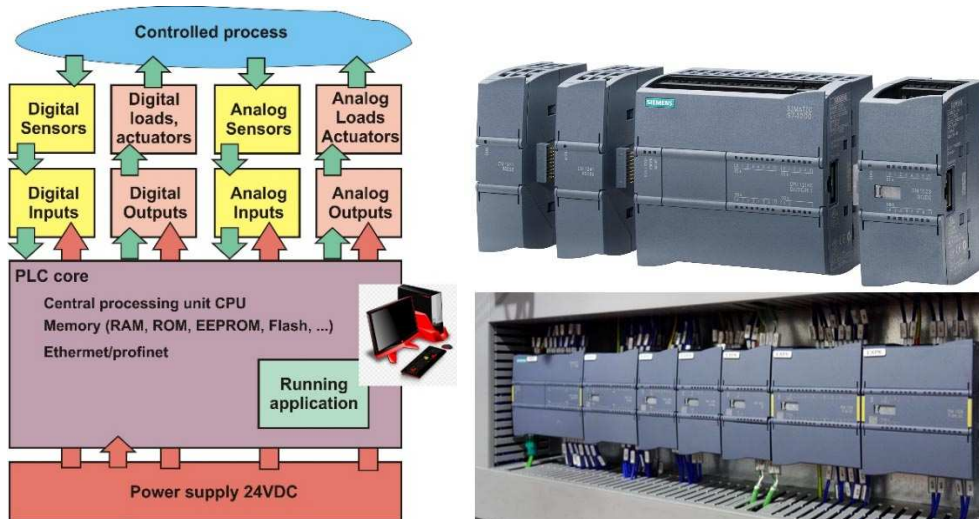

Fig. 2. Structure of PLC

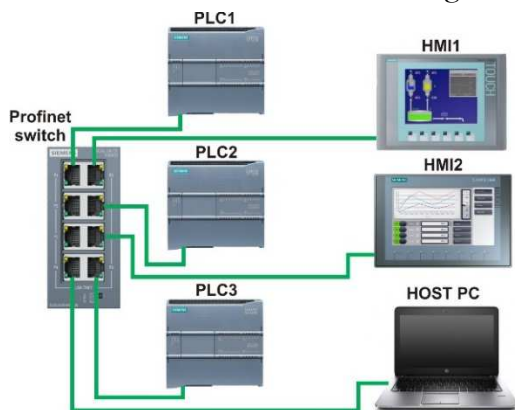

Fig. 3. Profinet network with more PLCs and HMIs



Fig. 4. Control system with PLC placed inside the rack cabinet with DIN rails

Normally, all modules are placed inside the industrial rack cabinet together with other electric components and modules (fig. 4). All parts in cabinet are fixed on DIN rails system.

After you download a program, the CPU contains the logic required to monitor and control the devices in your application. The CPU monitors inputs and changes of outputs according to the logic of this user program, which can include Boolean logic, counting, timing, complex math

operations, and communications with other intelligent devices. There are several ways how to develop program for PLC. The IEC 61131-3 [2] standard defines programming languages for programmable logic controllers (PLCs). This standard is under the control of CODESYS (Controller development system). This means that it is a development environment for programming PLC applications according to the international standard IEC 61131-3. Thanks to the IEC 61131-3 standard, we can create uniform data and program structures and control mechanisms independently of the manufacturer, PLC type, and regardless of the hardware used. The most frequently used languages for application developing are: Ladder Diagram (LD), Sequential Function Charts (SFC), Function Block (FBD), Structured Text (ST) and Instruction List (IL).

2. Training stand. Everything you need for an easy start is available Starter kits (fig. 5), which are available on the market. But it includes only pure PLC and HMI with Profinet cable and software for application developing.



Fig. 5. Starter kit without any accessories

The starter kit can be used immediately, but there are several aspects that need to be accepted. Assembly of the configuration is possible on the table, but carrying all modules with cables and other accessories is complicated then. Connection to a PLC screw terminal is also possible, but its repeated use can cause damage of the terminal and thus malfunction of the PLC, as the damaged terminal cannot be replaced. Connecting a host PC directly to the Profinet RJ-45 connector (included directly on PLC) is possible, but repeated connection and disconnection can destroy this PLC Profinet port and disable its further use. For practical training in the use of PLC, it was necessary to create a practical test stand that can be easily transferred and would form a compact unit to allow rapid creation of a prototype control system (fig. 6).



Fig. 6. Training PLC stand overall configuration (left); back side of stand with power supply and circuit breaker (middle); upper view to stand (right)

All components of training stand (fig. 6 and fig. 7) are placed on DIN rail system mounted on aluminium frame as compact device, which is easily movable. Also additional free DIN rail is available for extra selectable accessories. The training stand includes a total stop switch for turning the stand to off or on. The switch is backlit red when turned on. The stand includes ground fault protection and circuit breaker protection. The residual-current device (RCD) is located in the central electric cabinet in the laboratory. The central power supply (24V) and circuit breaker are located on the rear DIN rail. All high voltage terminals are insulated, so that they do not come into contact with live parts of the stand.

The HMI display is located at the top (fig. 7). The HMI and PLC are connected to the switch and the host PC can thus be connected to this switch and not to the PLC or HMI. This prevents damage to the RJ-45 terminal on the PLC and HMI.

The inputs and outputs of the PLC are connected to the extra terminal block and other devices will be connected to it so that the terminal block on the PLC is not damaged.



Fig. 7. Total red highlighted power switch (left); additional screw terminal (middle); Profinet switch (right)

3. Logic state hardware simulator. A logic hardware simulator (fig. 8) was created to simulate logic states at the PLC input. In addition to the commercially available signalling LEDs and buzzer on this simulator. The logic state at the input can be activated using a toggle switch or button. Signalling LEDs and a buzzer located on the simulator can be used to visualize the PLC outputs. This simulator allows you to debug the program in the PLC before connecting it to a real device and thus avoid errors and damage to the controlled device. In addition, it is possible to simulate atypical situations, which are difficult to induce on a controlled system and test the behaviour of the PLC with the program. The failure of the simulation will only alert us to an error in the program, but will not destroy the controlled device. We can fix our program and fix the errors.

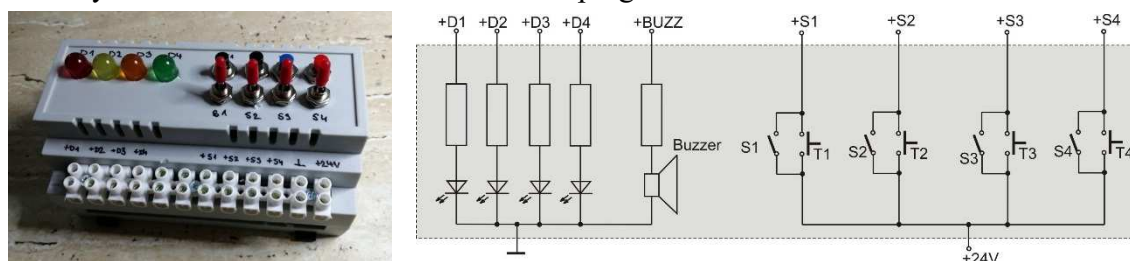

Fig. 8. Logical state hardware simulator

4. Traffic light application. The task is to make programme application and hardware realization with hardware simulator (fig. 9). There are time sequence defined for traffic light. It means that there is a time for green colour light, time for orange colour light and time for red colour light. The ladder diagram (fig. 10) consists of three timers, which defines time delay for every

colour. For complicated crossroad it is necessary to combine more lights from more sides of the crossroad. Ladder diagram is very intuitive programming, because it shows signal flow. Students also can connect logic state hardware simulator instead of real lights for testing of their program.

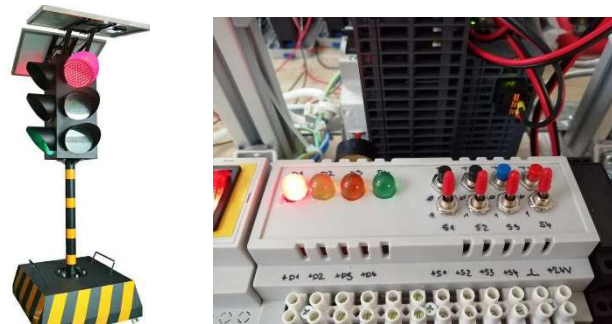

Fig. 9. Traffic light situation and hardware simulator

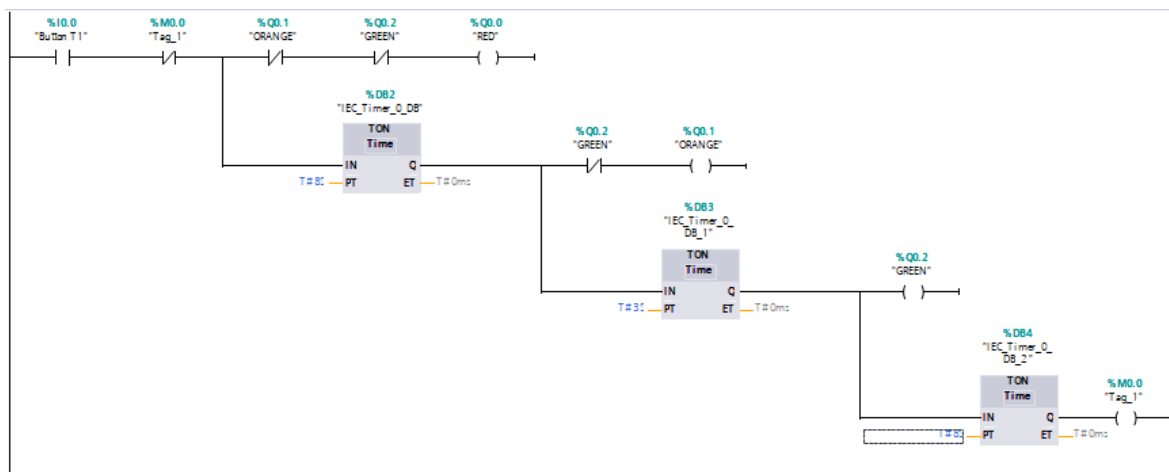

Fig. 10. Final ladder diagram for traffic light application

Conclusion. The proposed laboratory stand is a useful tool for teaching PLC control systems. It enables clear training of work with these systems. It is also possible to connect real or model hardware systems. Students will gain practical experience and skills that are essential for PLC programmers. At the same time, the test stand is a compact device that can be easily transferred and debugged on programs and applications for real controlled devices before being applied to real devices. A huge advantage is that it is possible to detect errors at an early stage of application development and it is even possible to simulate extreme situations, which is not possible with real devices.

Acknowledgement. The authors would like to thank to Slovak Grant Agency – project *KEGA 018TUKE-4/2018* supported by Ministry of Education of Slovak Republic.

References

1. TURLEY, J. (2020) Embedded Processors by the Numbers, EE Times, January 1999. Available online: <https://www.eetimes.com/embedded-processors-by-the-numbers/#>. Cited 09-01-2020.
2. LANDER, A. (2019) Programmable Logic Controllers: The Evolution of a Disruptive Technology. Engineering.com. Available online: <https://new.engineering.com/story/programmable-logic-controllers-the-evolution-of-a-disruptive-technology>. Cited 09-01-2020.
3. Barrett, M. (2008) The Design of a Portable Programmable Logic controller (PLC) Training System for Use Outside of the Automation Laboratory, International Symposium for Engineering Education, 2008, Dublin City University, Ireland, pp. 1-5.

УДК 004.4

Міхал Келемен, Пітер Ян Сінчак

**НАВЧАЛЬНІ СТЕНДИ ПРОГРАМОВАНИХ ЛОГІЧНИХ КОНТРОЛЕРІВ
ДЛЯ ОСВІТНІХ ЦІЛЕЙ**

Актуальність теми дослідження. Програмований логічний контролер – це пристрій для управління різними системами, зокрема в промисловості. Якщо керований пристрій складний, налагодити додаток складно через ризик його пошкодження. Для цього найкраще використовувати апаратний навчальний стенд для тестування розробленої вами програми.

Постановка проблеми. Стенд для тренувань – це компактний невеликий пристрій, який легко перенести в інше місце. Також це дозволяє з'єднати обладнання для тестування. Апаратний симулятор логічного стану також призначений для моделювання логічної системи з будь-якими вхідними даними за допомогою кнопок або перемикачів, а також із кольоровими індикаторами для візуалізації вихідних даних.

Аналіз останніх досліджень і публікацій. Навчальний пристрій дозволяє здійснити імітацію системи управління справжніми елементами перед практичним використанням у дорогій керуваній системі, де будь-яка помилка може призвести до величезних фінансових втрат, але помилки, що виникли під час моделювання на навчальному стенді, лише попереджають і показують слабе місце розробки.

Виділення недосліджених частин загальної проблеми. Питання мережевої побудови структур програмованих логічних контролерів є не дослідженими, тому на цьому буде зосереджене наступне дослідження.

Постановка завдання. Основна мета – створити компактний пристрій для навчання майбутніх розробників додатків з програмованим логічним контролером, який також можна було б використовувати розробниками-практиками, яким потрібно налаштувати програму перед тим, як встановити її в реальну роботу.

Виклад основного матеріалу. Існуючі навчальні пристрої великі та дорогі, їх непросто носити і не можна розширити. Робота з такими пристроями досить складна. Спроектований тренувальний стенд – це гнучкий та легко переносний пристрій.

Висновки відповідно до статті. Основна цінність полягає в тому, що студенти отримають практичний досвід та навички, необхідні програмістам PLC. Цей пристрій сприяє також креативності студентів, оскільки дозволяє змінювати апаратний склад. У ньому використовується система DIN-рейки, подібна до справжньої монтажної шафи. Стенд також включає людино-машинний інтерфейс для навчання практичному використанню цих пристроїв.

Ключові слова: програмований логічний контролер; управління; апаратне забезпечення; людино-машинний інтерфейс; реле.

Рис.: 10. Бібл.: 3.

Kelemen Michal – Prof. Ing., PhD., Faculty of Mechanical Engineering, Technical University of Kosice (Letna 9, 04200 Kosice, Slovakia).

E-mail: michal.kelemen@tuke.sk

Researcher ID: J-2845-2013

Scopus Author ID: 8396804800

ORCID ID: 0000-0003-2274-3828

Sinčák Peter Ján – Ing., PhD student, Faculty of Mechanical Engineering, Technical University of Kosice (Letna 9, 04200 Kosice, Slovakia).

E-mail: peter.jan.sincak@tuke.sk

ORCID ID: 0000-0002-6815-0262